

P5-16...R40-17

Model: N01

en Assembly and Operating Instructions

Roller shutter drive with integrated radio transceiver

Important information for:

- Fitters / • Electricians / • Users

Please forward accordingly!

These instructions must be kept safe for future reference.



2010 301 121 0b 05/12/2022



Table of contents

General	3
Warranty	4
Safety instructions	4
Instructions for the user	4
Instructions for installation and commissioning	4
Intended use	6
Assembling and disassembling the plug-in connecting cable	6
Assembly	7
Antenna installation	9
First operation	10
Programming transmitter	11
Clear transmitter	11
Checking that the running direction is correct	11
Intelligent installation management	11
Limit position status indicator	11
Setting the limit positions	12
Upper stop to lower stop	12
Upper point to lower point	12
Upper stop to lower point	13
Upper point to lower stop	13
Deleting the limit positions	14
Intermediate positions I + II	15
Programming additional transmitters	15
Deleting transmitters / window handles	16
Comfort ventilation function	16
Lock-out protection	16
Smoke alarm	16
Obstacle detection	16
Possible configurations with the Remote Commissioning Software	17
Remote Management (ReMan)	17
Remote Commissioning (ReCom)	17
Disposal	17
Maintenance	17
Technical data dia. 35	18
Technical data dia. 45	18
Supported profile	19
What to do if...?	19
Sample wiring diagram	20
Assignment table for the tubular drives	21
Declaration of conformity	22

General

These tubular drives are high-quality products with the following features:

- Optimised for roller shutter operation
- Individual, group and central radio control
- No need to run wires to a switch or relay control device
- Any combination of drive and transmitter possible
- Simple to set the limit positions with the transmitter
- Installation without stops possible (from upper point to lower point)
- Two freely selectable intermediate positions can be set
- Flexible radio grouping; can be altered at any time with no need to install/uninstall
- Automatic detection of the lower limit position when using springs in conjunction with the "drive adapter for obstacle detection"
- Automatic detection of limit positions thanks to intelligent electronic system with stop systems
- Obstacle detection, even when using anti-lifting devices (axle shaft devices)
 - Secure anti-lifting device
 - Slight pressure applied to the roller shutter curtain makes it difficult to raise or reach under it
 - Suitable for rigid aluminium, steel and wooden profiles
- The limit positions do not have to be reset: Changes in the shading solution are accommodated automatically when using stop systems.
- Torque control in the up direction prevents damage to the roller shutter in the event of a frozen or blocked shutter
- Anti-freeze mechanism in the upper limit position can be enabled
- Considerably reduced stop load, and thus considerably reduced shading solution load
- Smooth operation of the system and the drive increases the service life
- For plug-in connecting cable
- Fly screen protection function

Please observe these Assembly and Operating Instructions when installing and setting up the equipment.



The date of manufacture comes from the first four digits of the serial number.

The numbers 1 and 2 indicate the year and the numbers 3 and 4 indicate the calendar week.

Example: 34th calendar week in 2020

Ser. No.:	2034XXXXX
-----------	-----------

Explanation of pictograms

	CAUTION	CAUTION indicates a hazardous situation which, if not avoided, could result in injury.
	ATTENTION	ATTENTION indicates measures that must be taken to avoid damage to property.
		Denotes user tips and other useful information.



Warranty

Structural modifications and incorrect installation which are not in accordance with these and our other instructions can result in serious injuries, e.g., crushing of limbs. Therefore, structural modifications may only be carried out with our prior approval and strictly in accordance with our instructions, particularly the information contained in these Assembly and Operating Instructions. Any further processing of the products which does not comply with their intended use is not permitted.

The end product manufacturer and fitter have to ensure that all the relevant current statutory, official and, in particular, EMC regulations are adhered to during utilisation of our products, especially with regard to end product manufacture, installation and customer advice.

Safety instructions

The following safety instructions and warnings are intended to avert hazards and to prevent property damage and personal injury.

Instructions for the user

General information

- The drive must be disconnected from its power source during cleaning and maintenance and when replacing parts.
- All work, including maintenance and cleaning, on electrical installations as well as other system parts must always be performed by trained technicians, in particular qualified electricians.
- Children from the age of 8 years and persons with reduced physical, sensory or mental capabilities or lack of experience and/or knowledge may use these devices, provided they are supervised or have been instructed in the safe use of the device, and have understood the hazards involved. Children must not play with the device.
- Systems have to be checked regularly by authorised specialists for wear and damage.
- Always put damaged systems out of operation immediately until they are repaired by an authorised specialist.
- Do not operate equipment if people or objects are within the danger zone.
- Observe the danger zone of the equipment during operation.
- Ensure that there is adequate clearance (at least 40 cm) between moving parts and adjacent objects.



Caution

Safety instructions for avoiding serious injuries.

- **Crushing or shearing points must be avoided or protected.**

Instructions for installation and commissioning

General information

- Observe the safety instructions in EN 60335-2-97. Please note that this list of safety instructions is not exhaustive, since it would be impossible for the standard to include all sources of danger. For example, the design of the operated product, the way the drive works in the situation it is installed in or even the way the end product is mounted in the end user's place of use cannot be taken into consideration by the drive manufacturer.
If any questions or uncertainties regarding the safety instructions contained in the standard arise, please contact the manufacturer of the part or end product in question.
- All applicable standards and regulations for electrical installation must be complied with.
- All work, including maintenance and cleaning, on electrical installations as well as other system parts must always be performed by trained technicians, in particular qualified electricians.
- Only use spare parts, tools and accessory devices which have been approved by the drive manufacturer.
Unapproved third-party products or modifications to the system and its accessories represent a risk to your safety and the safety of others. This means that the use of unapproved third-party products, or modifications which have not been agreed with or approved by us, are prohibited. We do not accept liability for damage or injury arising from such actions.
- Position switch with OFF presetting within sight of the driven product, but away from moving parts, at a height of over 1.5 m. This must not be publicly accessible.
- Permanently mounted control devices must be positioned where they can be seen.
- Rated torque and duty cycle must be suitable for the requirements of the driven product.
Technical data - rated torque and service life can be found on the type plate of the tubular drive.

- Hazardous moving parts of the drive must be installed at a height of over 2.5 m above floor level or any other surface from which the drive can be accessed.
- To ensure safe operation of the system after commissioning, the limit positions must be correctly set/programmed in.
- Drives with a H05VV-F connecting cable may only be used indoors.
- Drives with a H05RR-F, S05RN-F or 05RN-F connecting cable may be used both indoors and outdoors.
- To connect the drive to the driven part, solely mechanical accessory components made by the drive manufacturer from the current product catalogue may be used. The components must be installed in accordance with the manufacturer's instructions.
- If the drive is used for shading solutions in a specially marked area (e.g., escape routes, hazard zones, safety areas), compliance with all applicable regulations and standards must be ensured.
- Once the drive has been installed, the fitter must mark the used tubular drive in the "Technical data" chapter and make a note of the installation position.



Caution

Safety instructions for avoiding serious injuries.

- **When electrical or electronic equipment and units are operated, certain components, e.g., the power supply unit, are live. Physical injuries or damage to property can result in the event of unauthorised interventions or failure to heed warnings.**
- **Be careful when touching the tubular drive, as it heats up during operation for technical reasons.**
- **Before installation, shut down all lines and control devices that are not essential for operation.**
- **Crushing or shearing points must be avoided or protected.**
- **When installing the drive, all-pole disconnection from the mains with a contact gap of at least 3 mm per pole must be provided (EN 60335).**
- **If the mains connecting cable is damaged, it may only be replaced by the manufacturer. If the drive has a plug-in connecting cable, it must be replaced with the same type of mains connecting cable, which is available from the drive manufacturer.**

Attention

Safety instructions for avoiding property damage.

- **Ensure that there is adequate clearance between moving parts and adjacent objects.**
- **The drive must not be carried by the mains connecting cable.**
- **All latching connections and fastening screws on the brackets must be checked to ensure that they are secure.**
- **Ensure that nothing rubs against the tubular drive, such as shading solution attachments, screws, etc.**
- **The drive must be fitted horizontally.**



Intended use

The type of tubular drive described in these instructions is intended solely for the operation of roller shutters. This tubular drive type is compatible with the EnOcean wireless standard and uses the profiles mentioned in the chapter "Supported profiles". This type of tubular drive supports not only curtain attachment by means of springs but also rigid shaft connectors, such as mechanical anti-lifting devices manufactured by Zurfluh-Feller, Simu, GAH Alberts and Deprat. These are detected automatically. If the springs or the top lath are screwed or riveted to the barrel, a point must be set in the lower limit position.

When mounting connection parts on the drive dia. 35 mm PXX/XX, only use screws EJOT Delta PT 40x12 WN 5454 Torx (9900 000 545 4).

For sun protection, please only use the types of tubular drive specifically designed for this purpose.

This type of tubular drive is designed for use in single systems (one drive per barrel).

The tubular drive must not be used in potentially explosive areas.

The connecting cable is not suitable for transporting the drive. Always carry the drive by the housing tube.

Other applications, uses and modifications are not permitted in order to protect the safety of the users and others, since these actions can impair the system's safety and carry the risk of personal injury and property damage. The drive manufacturer does not accept liability for damages or injury arising from such actions.

Always observe the information in these instructions when operating or repairing the system. The drive manufacturer does not accept liability for damage or injury resulting from improper usage.

Attention

Only use rigid shaft connectors if the roller shutter laths are sufficiently strong. The closed curtain must not project beyond the guide tracks or else there is a risk of the joint between the top two laths being subjected to excessive strain and getting damaged.

Assembling and disassembling the plug-in connecting cable



Caution

The power supply to the connecting cable must be disconnected prior to assembly/disassembly.

Assembling the plug-in connecting cable

Ø35/Ø45/Ø58

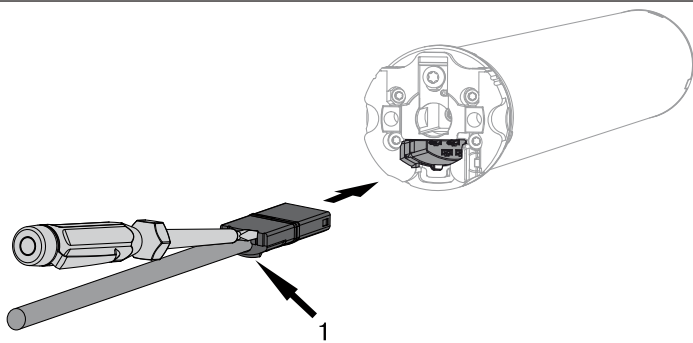

1 = locating lug

Insert the **dead** connecting cable into the drive head until the locating lug clicks into place in the drive. If necessary, use a suitable flathead screwdriver to assist with insertion. Set the screwdriver into one of the two plug grooves provided for this purpose.

Check that the cable is properly engaged.

Disassembling the plug-in connecting cable for tubular drives

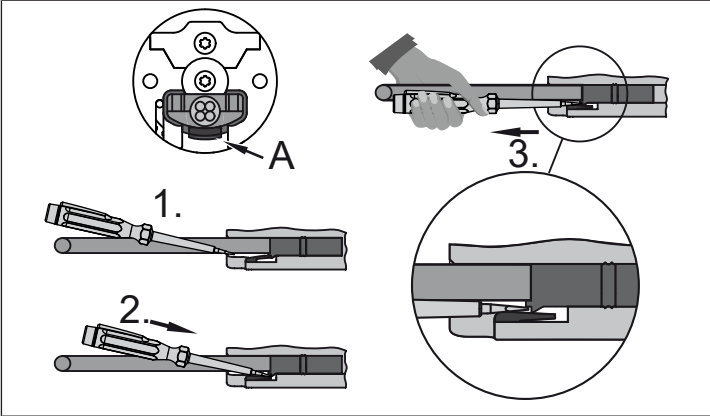
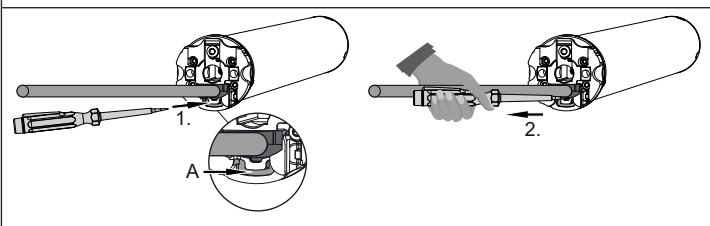
<p style="text-align: center;">Ø35</p> 	<p>Insert a suitable flathead screwdriver between the locating lug and the snap-in pin, so that the snap-in pin releases the locating lug from the plug.</p> <p>Now you can pull out the connecting cable along with the flat-head screwdriver.</p>
<p>A = snap-in pin</p>	
<p style="text-align: center;">Ø45/Ø58</p> 	<p>Insert a suitable flathead screwdriver right into the recess of the locating latch, so that the latch releases the locating lug from the plug.</p> <p>Now you can pull out the connecting cable along with the flat-head screwdriver.</p>
<p>A = locating latch</p>	

Assembly

Assembling the drive

Attention

To connect the drive to the driven part, solely mechanical accessory components made by the drive manufacturer from the current product catalogue may be used.

Prior to mounting, the fitter must ensure that the masonry and the system being motorised are sufficiently robust (drive torque plus weight of the shading solution).



Caution

Electrical connections may only be carried out by a qualified electrician. Prior to assembly, the power supply must be disconnected and secured. Please give the enclosed connection information to the responsible electrical contractor.

If you want the roller shutter curtain to open to the upper stop, proceed as follows: The roller shutter curtain must be prevented from being drawn into the shutter box with a mechanical stop or an angled end strip. With face-fixed elements, we recommend concealed stops in the guide tracks.

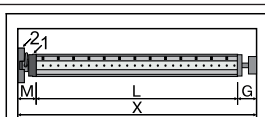

Calculate the space required at the side (M) by measuring the drive head (1) and wall bracket (2). The clear dimension of the box (X) minus the space required at the side (M) and idler (G) gives the length (L) of the barrel: $L = X - M - G$.

The space required at the side (M) varies depending on the combination of drive and wall bracket.

Then mount the wall bracket and idler. Ensure that the barrel is aligned at right angles to the wall and that sufficient axial play is allowed for the mounted system.

Attention

When using rigid shaft connectors, closed brackets must be fitted. The tubular drive presses the closed curtain down to make it difficult for people to reach under it or raise it. Only use curtains made of sufficiently strong material, such as aluminium, steel or wood. To prevent damage to the curtain it must run in guide tracks from top to bottom.



Assembling and disassembling the mounting pin

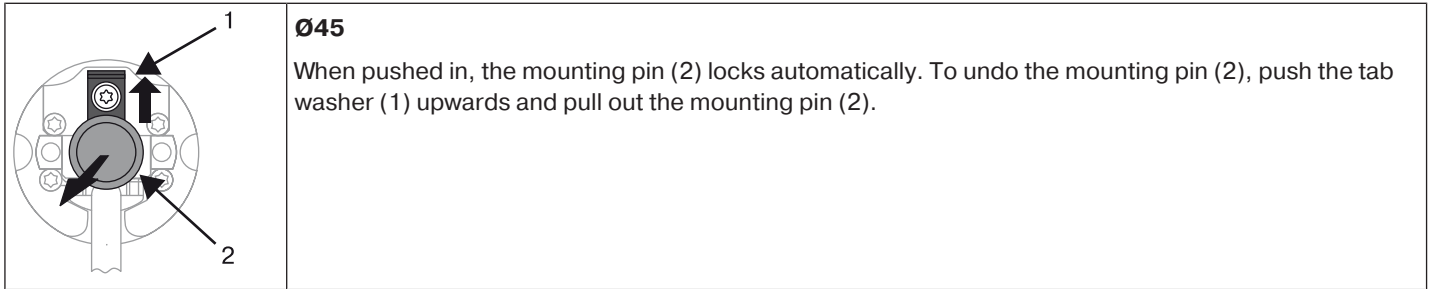

i If you wish to use the "obstacle detection" function, you must use the "drive adapter for obstacle detection".

Assembling and disassembling the drive adapter

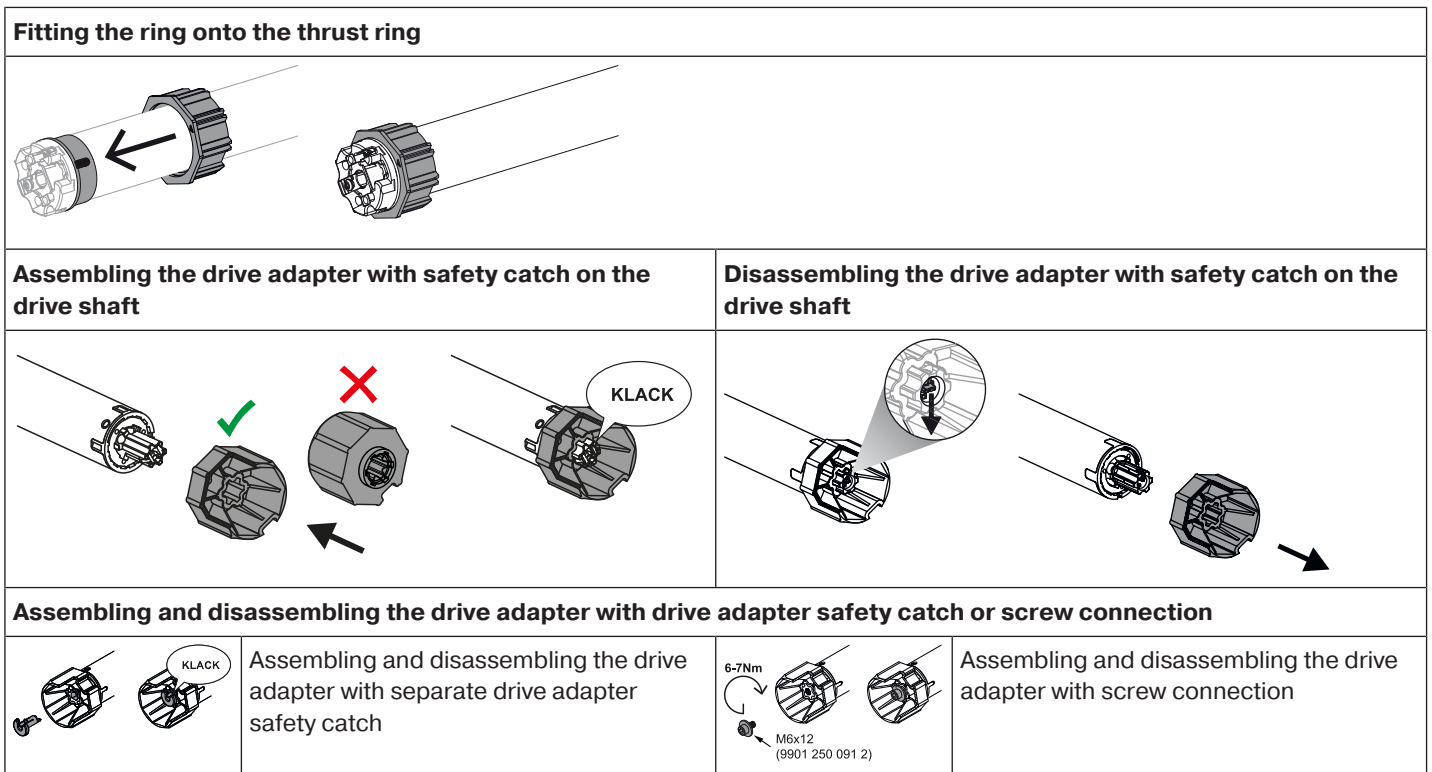

Mounting the drive in the tube

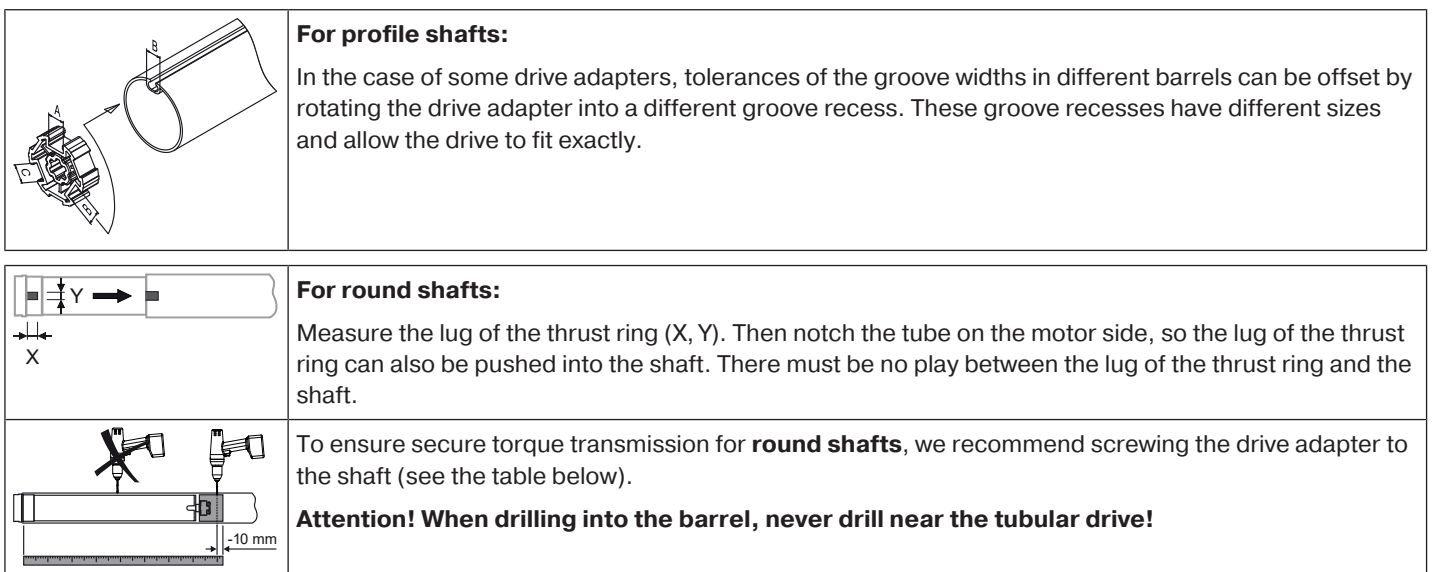

Size of drive [mm]	Drive adapter	Torque max. [Nm]	Fastening screws (4 units)
dia. 35-dia. 45	All	Up to 50	Self-tapping screw dia. 4.8 x 9.5 mm

We also recommend screwing the idler to the barrel.

Attention

Do not hammer the tubular drive into the tube or drop it into the barrel! The curtain can only be secured using springs or rigid shaft connectors. We recommend at least three pieces per metre of barrel.



Assemble the tubular drive with the relevant ring (1) and drive adapter (2). If the ring has several grooves, select the groove which is a perfect fit and push the ring (1) onto the thrust ring.

Insert the tubular drive with the pre-assembled ring (1) and drive adapter (2) into the tube to achieve a form fit. Ensure that the ring and drive adapter are secure in the tube.

Mount the assembled unit comprising shaft, tubular drive and idler on the box and secure the drive with a splint or spring pin according to the type of wall bracket fixing.

Position the barrel so that the roller shutter curtain can be attached with springs or fit the rigid shaft connectors in accordance with the manufacturer's instructions.

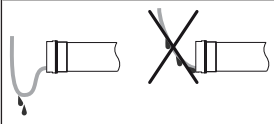

Lay the connecting cable

Lay the connecting cable up to the tubular drive, and fix The connecting cable and any antennae must not project into the winding chamber. Cover any sharp edges.

Antenna installation

Lay and fix the antenna end in the lower part of the box near the guide rail.

Attention

Make sure that the antenna cannot be detected by the roller shutter curtain.

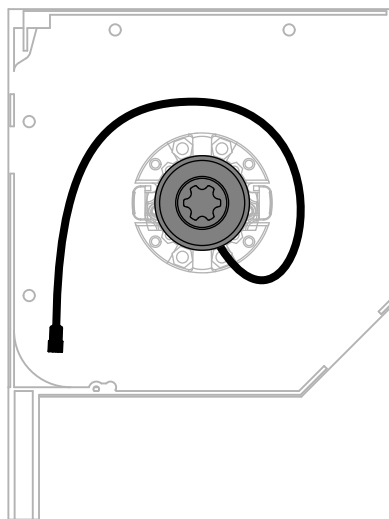

First operation

Explanation of symbols

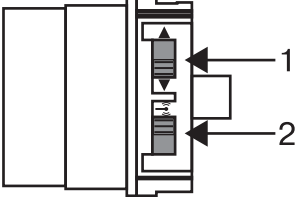
▲	UP button
■	STOP button
▼	DOWN button
●	Programming button (on the transmitter)
(M) ...X	Receiver confirms once or multiple times by "clicking" or "shifting"
	1 = direction switch 2 = radio switch

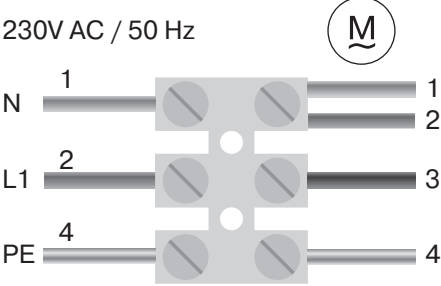
<p>230V AC / 50 Hz</p> 	<p>Connecting the tubular drive</p> <p>Connect the tubular drive to the power supply.</p>				
<table border="1" style="width: 100%;"> <tr> <td>1 = blue</td> <td>3 = black</td> </tr> <tr> <td>2 = brown</td> <td>4 = green / yellow</td> </tr> </table>	1 = blue	3 = black	2 = brown	4 = green / yellow	
1 = blue	3 = black				
2 = brown	4 = green / yellow				

	<p>(M) 1x</p>	<p>Readying the tubular drive for programming</p> <p>Switch on the power.</p> <ul style="list-style-type: none"> ▶ The tubular drive confirms. ▶ The tubular drive is ready to program for 3 minutes
--	---------------	---

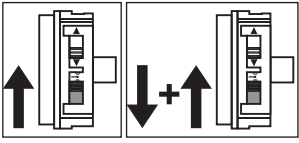
	<p>(M) 1x</p>	<p>Readying the tubular drive for programming with the radio switch</p> <p>Switch the radio switch to the inside position. If the radio switch is already in this position, switch it to the outside and back to the inside position.</p> <ul style="list-style-type: none"> ▶ The tubular drive confirms. ▶ The tubular drive is ready to program for 3 minutes
--	---------------	---

i If several tubular drives are to be connected in parallel, you can deactivate the programming mode on one tubular drive by switching the radio switch to the outside position after turning the power on.

<p>▲ / ▼ 1s</p>	<p>Deactivate the tubular drive from the programming mode</p> <p>Press a travel button for 1 second on a transmitter that has already been programmed.</p> <ul style="list-style-type: none"> ▶ The tubular drive is deactivated from programming mode. There is no confirmation.
-----------------	---

Programming transmitter

		Put the tubular drive into programming mode.
3x ▲ / 3x ▼ <2s		Press a travel button 3 times within two seconds. <ul style="list-style-type: none"> ▷ The tubular drive confirms. ▶ Programming is now complete.

Clear transmitter

		Put the tubular drive into programming mode.
3x ▲ / 3x ▼ <2s		Press a travel button 3 times within two seconds. <ul style="list-style-type: none"> ▷ The tubular drive confirms. ▶ The clearing process is now complete.

Checking that the running direction is correct



The direction of rotation can only be changed if no limit position has been set.

Press the UP or DOWN button

- ▷ The shading solution runs in the desired direction.
- ▶ Direction switch is OK.

If the shading solution runs in the wrong direction, the running direction must be switched. Proceed as follows:

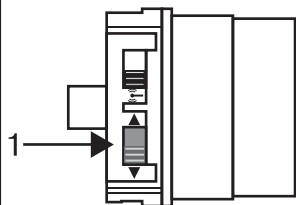
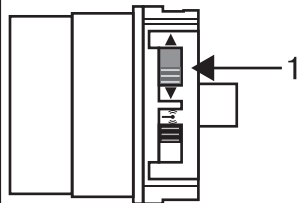

Switch the direction switch (1) to the opposite position.

- ▶ The shutter direction is now changed.
- Check the shutter direction again.

Intelligent installation management

Completion of installation following automatic setting of limit positions

The drive saves the limit position permanently once the upper limit position is reached 3 times in succession. Installation is then complete. If the limit position is set above a point, this is stored permanently.

Limit position status indicator

A brief stopping and restarting indicates that no limit position has been set in that direction of movement.



Setting the limit positions

i The running direction must be correct. When setting the limit positions, the tubular drive runs in dead-man mode with the limit position status indicator. The upper limit position must always be set first. When setting the upper limit position, ensure that the roller shutter curtain is not pulled out of the guide tracks.

When first installing using springs and adjusting the limit position "...to lower stop", the barrel in the lower limit position turns approx. 1/4 of a turn further than usual. In doing so, the tubular drive is able to automatically detect the use of anti-lifting devices or springs. The tubular drive switches off automatically.

Attention

When operating the tubular drive without the drive adapter for obstacle detection, if using springs a point must be set in the lower limit position.

There are several ways to set the limit positions:

- Upper stop to lower stop
- Upper point to lower point
- Upper stop to lower point
- Upper point to lower stop

The limit position becomes fixed after the tubular drive has turned off **automatically** in the desired position three times.

Upper stop to lower stop

i When setting the limit positions, the tubular drive runs in maintained operation with the limit position status indicator.

▲	Open to the permanent upper stop. ▷ The tubular drive switches off automatically.
▼	Then close to the permanent lower stop. ▷ The tubular drive switches off automatically. ▶ The limit positions are now set.

Upper point to lower point

i There is no shading solution length adjustment with this limit position setting.

		Put the tubular drive into programming mode.
▲/▼ >5s	(M) 2x	Press a travel button for >5 seconds on a transmitter that has already been programmed in order to switch to installation mode. ▷ The tubular drive confirms. i A drive command is executed when a button is pressed for more than 1 second.
▲		Open to the desired upper limit position.
2x ▲ <1s	(M) 1x	Press the UP button twice within one second to set the point. ▷ The tubular drive confirms.
▼		Then close to the desired lower limit position.
2x ▼ <1s	(M) 1x	Press the down button twice within one second to set the point. ▷ The tubular drive confirms. ▶ The limit positions are now set.

4x ▲ / 4x ▼ <1s	(M) 3x	Press a travel button 4 times within one second to exit the installation mode. ▶ The tubular drive confirms.
-----------------	--------	---

Upper stop to lower point

▲		Open to the permanent upper stop. ▷ The tubular drive switches off automatically.
		Put the tubular drive into programming mode.
▲ / ▼ >5s	(M) 2x	Press a travel button for >5 seconds on a transmitter that has already been programmed in order to switch to installation mode. ▷ The tubular drive confirms. i A drive command is executed when a button is pressed for more than 1 second.
▼		Then close to the desired lower limit position.
2x ▼ <1s	(M) 1x	Press the down button twice within one second to set the point. ▷ The tubular drive confirms. ▶ The limit positions are now set.
4x ▲ / 4x ▼ <1s	(M) 3x	Press a travel button 4 times within one second to exit the installation mode. ▶ The tubular drive confirms.

Upper point to lower stop

		Put the tubular drive into programming mode.
▲ / ▼ >5s	(M) 2x	Press a travel button for >5 seconds on a transmitter that has already been programmed in order to switch to installation mode. ▷ The tubular drive confirms. i A drive command is executed when a button is pressed for more than 1 second.
▲		Open to the desired upper limit position.
2x ▲ <1s	(M) 1x	Press the UP button twice within one second to set the point. ▷ The tubular drive confirms.
▼		Then close to the permanent lower stop. ▷ The tubular drive switches off automatically. ▶ The limit positions are now set.
4x ▲ / 4x ▼ <1s	(M) 3x	Press a travel button 4 times within one second to exit the installation mode. ▶ The tubular drive confirms.



Deleting the limit positions

Attention

When the limit positions are deleted, all the other set functions (intermediate position I, intermediate position II, upper anti-freeze mechanism, obstacle detection, fly screen protection function) are deleted as well.



Deleted limit positions are displayed on the limit position status indicator.

Deleting a limit position when 2 limit positions are programmed

		Put the tubular drive into programming mode.
▲/▼ >5s	(M) 2x	Press a travel button for >5 seconds on a transmitter that has already been programmed in order to switch to installation mode. ▶ The tubular drive confirms i A drive command is executed when a button is pressed for more than 1 second.
▲/▼		Move the shading solution to the limit position that is to be deleted.
Carry out the following sequence without interruption between the individual drive commands.		
▲ 0,5s	▼ 0,5s	▼ 0,5s
▲ 0,5s	▼ 0,5s	▲ 0,5s
▲ 0,5s	▲ 0,5s	▼ until
	(M) 2x	■ STOP
4x ▲ / 4x ▼ <1s	(M) 3x	Press a travel button 4 times within one second to exit the installation mode. ▶ The tubular drive confirms.





Deleting both limit positions

		Put the tubular drive into programming mode.
▲/▼ >5s	(M) 2x	Press a travel button for >5 seconds on a transmitter that has already been programmed in order to switch to installation mode. ▶ The tubular drive confirms i A drive command is executed when a button is pressed for more than 1 second.
▲/▼		Open/close the shading solution to a point between the limit positions.
Carry out the following sequence without interruption between the individual drive commands.		
▲ 0,5s	▼ 0,5s	▼ 0,5s
▲ 0,5s	▼ 0,5s	▲ 0,5s
▲ 0,5s	▲ 0,5s	▼ until
	(M) 2x	■ STOP
4x ▲ / 4x ▼ <1s	(M) 3x	Press a travel button 4 times within one second to exit the installation mode. ▶ The tubular drive confirms.



Intermediate positions I + II

i The intermediate positions I + II are freely selectable positions for the shading solution between the two limit positions. Each travel button can be assigned one intermediate position. Both limit positions must be set before an intermediate position is set.



Setting the desired intermediate position

 / 		Use a short drive command to move the shading solution in the direction of the desired intermediate position.
 /  5s	 1x	At the desired intermediate position, press the corresponding travel button while moving for 5 seconds. <ul style="list-style-type: none"> ▷ The tubular drive confirms. ▶ The intermediate position is now saved.

Travelling to the desired intermediate position



2x  / 2x  <1s		Press the travel button for the desired intermediate position twice within one second. <ul style="list-style-type: none"> ▶ The curtain runs to the intermediate position assigned to the travel button.
---	--	---

Deleting the desired intermediate position



 /  5s	 2x	Press the travel button assigned to the intermediate position for 5 seconds. <ul style="list-style-type: none"> ▷ The shading solution moves to the intermediate position and the tubular drive confirms. ▶ The intermediate position is now deleted.
--	--	---

Programming additional transmitters

i Up to 14 transmitters can be programmed into the tubular drive.

		Put the tubular drive into programming mode.
3x  / 3x  <2s	 2x	Press a travel button 3 times within 2 seconds on the transmitter to be programmed. <ul style="list-style-type: none"> ▷ The tubular drive confirms. ▶ The new transmitter has now been programmed.

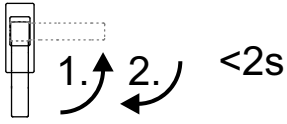
Programming of window handles with EnOcean wireless technology

		Put the tubular drive into programming mode.
 <2s	 2x	Move the window handle from the CLOSED position to OPEN and back to CLOSED within 2 seconds. <ul style="list-style-type: none"> ▷ The tubular drive confirms. ▶ The window handle has now been programmed.





Deleting transmitters / window handles

Deleting transmitters

		Put the tubular drive into programming mode.
3x ▲ / 3x ▼ <2s	 2x	Press a travel button 3 times within 2 seconds on the transmitter to be deleted. <ul style="list-style-type: none">▷ The tubular drive confirms.▶ The transmitter has now been deleted.

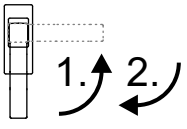
Deleting window handles

		Put the tubular drive into programming mode.
 <2s	 2x	Move the window handle from the CLOSED position to OPEN and back to CLOSED within 2 seconds. <ul style="list-style-type: none">▷ The tubular drive confirms.▶ The window handle has now been deleted.

Comfort ventilation function



A prerequisite for the ventilation function is that an intermediate position II is set.

If the shading solution is below intermediate position II and a programmed window handle with EnOcean wireless technology is turned to the "tilted" position, the shading solution moves to intermediate position II.

If the window handle is turned back to the "closed" position, the shading solution moves to the original position.

If the shading solution has been moved in the meantime and the window handle is turned to the "closed" position, the shading solution will not move to the original position.

Lock-out protection

The lock-out protection is deactivated on delivery and can only be activated via ReMan.

If the window handle is turned to the "open" position, the down cycle is blocked.

Smoke alarm



In the event of a smoke alarm, the roller shutter moves to the upper end position and the down cycle is blocked.

When an alarm signal is given from a programmed smoke detector, the shading solution moves to the upper end position. Smoke detectors can only be programmed via ReMan.

Obstacle detection



Caution

Obstacle detection is only active in conjunction with the "drive adapter for obstacle detection".

In addition, please note that the drive must be pushed in to the shaft as far as the band of the thrust ring.

Use of the drive's obstacle detection system as personal protection is not permitted. It has been designed exclusively to protect the roller shutters or sun protection system from being damaged.

If the drive is correctly installed, it switches off when it detects obstructions or shutter faults and reverses a short way in the opposite direction and thus away from the obstacle.

If reversing is interrupted, a further drive command is only possible in the direction of reversing. Travel the shading solution without interruption until the tubular drive stops automatically. It is now possible to travel in both directions again.

The following are detected:

Moving DOWN

- A curtain jam when closing due to objects on the window sill or sticking of the lateral guide tracks.

To ensure complete closing of the roller shutter curtain at the lower limit position, the curtain does not reverse once it gets to approx. 360° from the lower limit position.

To ensure that the roller shutter curtain safely enters the guide tracks, obstacle detection is inactive for approx. 1.5 revolutions of the barrel from the upper limit position.

Moving UP

- Extremely large increase in the load (e.g., ice on the end strip)

Possible configurations with the Remote Commissioning Software

Please find the appropriate description in the instructions for the software.

- Upper anti-freeze mechanism
- Fly screen protection function
- Repeater mode Level 1 and Level 2
- Lock-out protection
- Programming smoke alarm
- Activating / deactivating the programming mode by switching on the power
- Set tubular drive to installation mode
- Running direction

Remote Management (ReMan)



The functions LOCK, UNLOCK and SET CODE are only available 5 minutes after switching on the mains voltage for the factory-set security code.

The factory-set **security code** is: **1F5340B9** and **must** be changed for further use of ReMan / ReCom. Please ensure you keep the current security code in a safe place for future reference.

Resetting the security code is only possible with the universal adjustment set (Item no. 4935 000 001 0). To do this, connect the universal adjustment set to the tubular drive and press the "Delete transmitter" button for 10 seconds. The tubular drive confirms. The tubular drive supports the following ReMan functions:

- PING
- LOCK, UNLOCK, SET CODE
- QUERY ID, QUERY STATUS
- ACTION (clicks once when triggered)

These functions are used to secure access to the tubular drive, to address it initially via wireless communication and subsequently to enable Remote Commissioning functionality.

Information about the individual ReMan functions can be found in the Remote Management Specification of EnOcean GmbH.

Remote Commissioning (ReCom)

The tubular drive supports EnOcean Alliance standardized Remote Commissioning functions. Details on these functions are documented in the current Remote Commissioning System Specification of the EnOcean Alliance.

Disposal



The crossed-out bin symbol on the product indicates that the device is subject to mandatory disposal separate from household waste. This product must be handed over to a collection point for electrical and electronic equipment at the end of its service life. The packaging material must be disposed of properly.

Maintenance

These drives are maintenance-free.



Technical data dia. 35

Tubular drive	P5-16	P9-16
Model	N01	
Type	C PROF3+	
Rated torque [Nm]	5	9
Output speed [rpm]	16	16
Limit switch range	64 revolutions	
Supply voltage	230 V AC / 50 Hz	
Connected load [W]	85	110
Rated current consumption [A]	0.36	0.47
Operating mode	S2 4 min.	
Degree of protection	IP 44	
Min. tube inside diameter [mm]	37	
Frequency	868.3 MHz	
Emission sound pressure level [dB(A)]	≤ 70	

Technical data dia. 45

Tubular drive	R8-17	R12-17	R20-17	R30-17	R40-17
Model	N01				
Type	C PROF3+				
Rated torque [Nm]	8	12	20	30	40
Output speed [rpm]	17	17	17	17	17
Limit switch range	64 revolutions				
Supply voltage	230 V AC / 50 Hz				
Connected load [W]	100	110	160	205	260
Rated current consumption [A]	0.45	0.5	0.75	0.9	1.15
Operating mode	S2 4 min.				
Degree of protection	IP 44				
Min. tube inside diameter [mm]	47				
Frequency	868.3 MHz				
Emission sound pressure level [dB(A)]	≤ 70				

Supported profile

Profile no.	Type	Description
F6-02-01	RPS	Rocker Switch, 2 Rocker Light and Blind Control - Application Style 1
F6-03-01	RPS	Rocker Switch, 4 Rocker Light and Blind Control - Application Style 1
D2-05-02	VLD	Blind Controls for Position and Angle Type 0x02
F6-05-00	RPS	Wind Speed Threshold Detector
F6-10-00	RPS	Mechanical Window Handle
D5-00-01	1BS	Contacts and Switches Single Input Contact
F6-05-02	RPS	Smoke Detector

What to do if...?

Problem	Remedy
Tubular drive does not move.	Program new transmitter.
	Bring transmitter within range of the tubular drive.
	Check electrical connection.
	Thermal protection switch in tubular drive has tripped. Wait until the thermal protection switch in the tubular drive is reactivated.
Running direction on tubular drive cannot be set.	Delete limit positions (see chapter Deleting limit positions) and reset the running direction.
Incorrect running direction after deleting limit positions.	Use ReCom or the direction switch on the tubular drive to change the direction of rotation.
Tubular drive stops arbitrarily; cannot be restarted in the same direction.	Tubular drive has detected an increase in load. Briefly run the curtain in the opposite direction, then continue in the desired direction.
	Tubular drive is overloaded. Use a higher-torque tubular drive.
	Delete limit positions, then reprogram limit positions.
During the programming run, the drive stops short of the limit position to be programmed.	For safety reasons, the drive reacts sensitively to sluggishness during the programming run, in order to prevent damage. Briefly run curtain DOWN and subsequently UP until you reach the upper limit position.
Ventilation slots of the roller shutter do not close fully.	Delete the limit positions (see Deleting limit positions) and then set the limit positions as per "to lower point" (see chapter Setting the limit positions); in this case, set the lower limit position first (lower point) followed by the upper limit position.
Forgotten security code.	Press the "Delete transmitter" button on the Becker universal programming unit (item no. 4935 000 001 0) for 10 seconds to reset the security code to the factory setting.



Sample wiring diagram

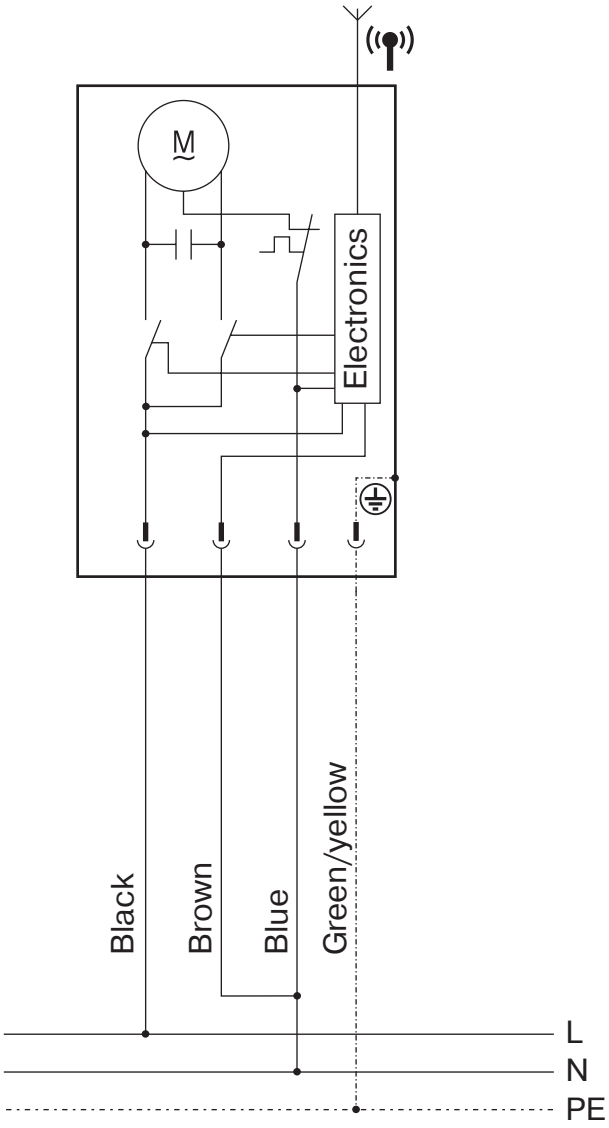

Declaration of conformity

BECKER-ANTRIEBE GMBH
Friedrich-Ebert-Str. 2 - 4
35764 Sinn, Germany



BECKER

– Original –

EU Declaration of Conformity

Document No./ Month.Year: **K005/12.21**

We hereby declare that the following product series

Product designation: **Tubular motor**

Type designation: **P5/16..., P5/20..., P5/30..., P9/16...,
R8/17..., R12/17..., R20/17..., R30/17..., R40/17..., R50/11...,
L50/17..., L60/11..., L60/17..., L70/17..., L80/11..., L80/17...,
L120/11..**

Version: **C, R, S, F, P, E, O, KNX, PLUS, EN, A0...Z9, +**

From serial number: **from 220100001**

complies with the applicable regulations of the following Directives:

Directive 2006/42/EG (MD) L157, 09.06.2006

Directive 2014/53/EU (RED) L153, 22.05.2014

Directive 2011/65/EU (RoHS) L174, 01.07.2011

Furthermore, the safety objectives of the **Low Voltage Directive 2014/35/EU** as per Appendix I No.1.5.1 of Directive 2006/42/EC have been met.

Applied standards:

**DIN EN 60335-1:2020
EN 60335-2-97:2017**

**EN 300220-2:2017
EN 301489-3:2019**

EN 62479:2011

EN 14202:2004

Authorised party for the compilation of the technical documentation:
Becker-Antriebe GmbH, Friedrich-Ebert-Str. 2 - 4, 35764 Sinn, Germany

This declaration of conformity was issued:

Sinn, 17.12.2021
Place, Date



Jürgen Timm, Management

This declaration certifies compliance with the Directives cited but does not represent any assurance of characteristics. The safety warnings in the supplied product documentation must be observed!

K005_en



Initial setup - tubular drive - Type N01

Setup with transmitter

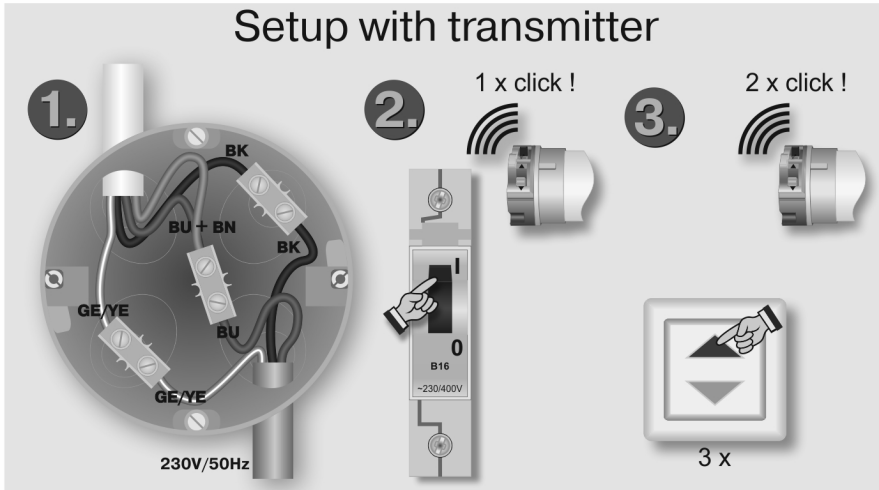

direction of rotation

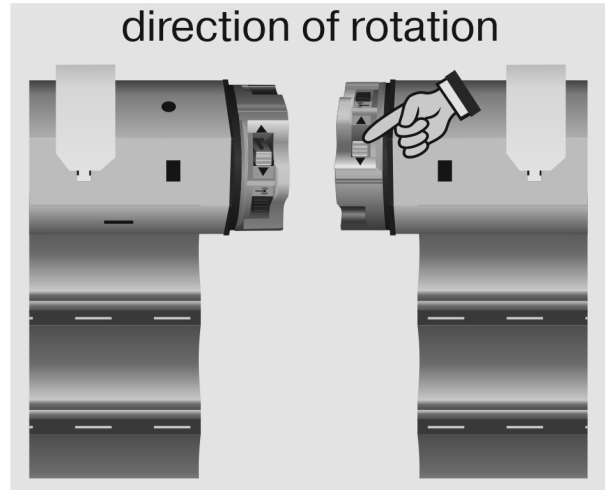

Mechanical End Limit Position

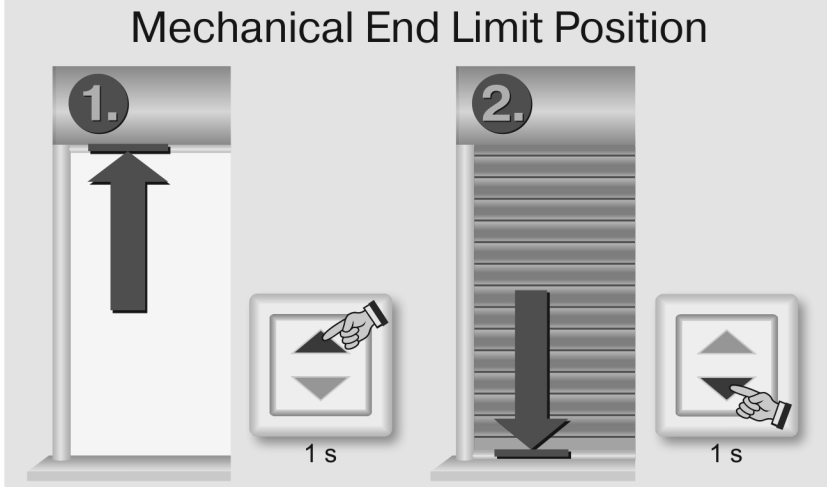

Installation Mode

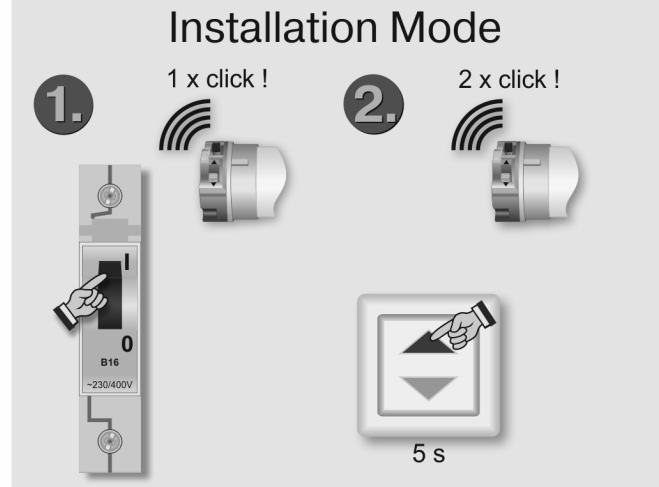

End Limit Point - Setting /

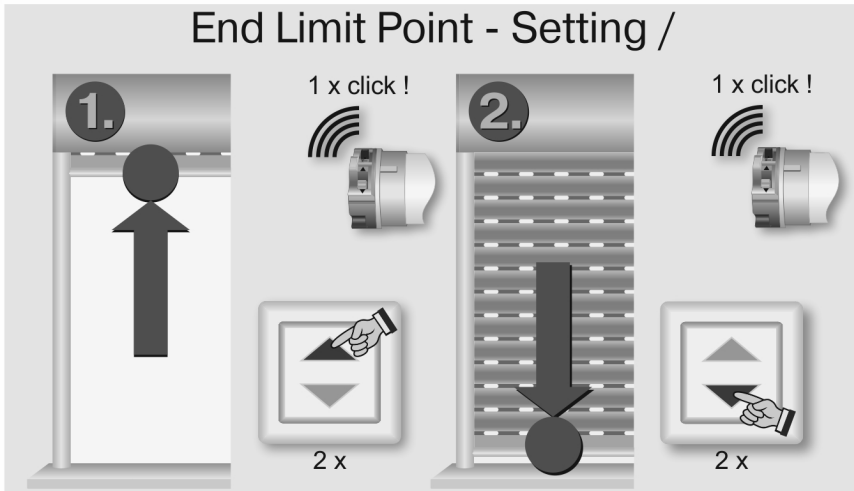

Delete limit positions

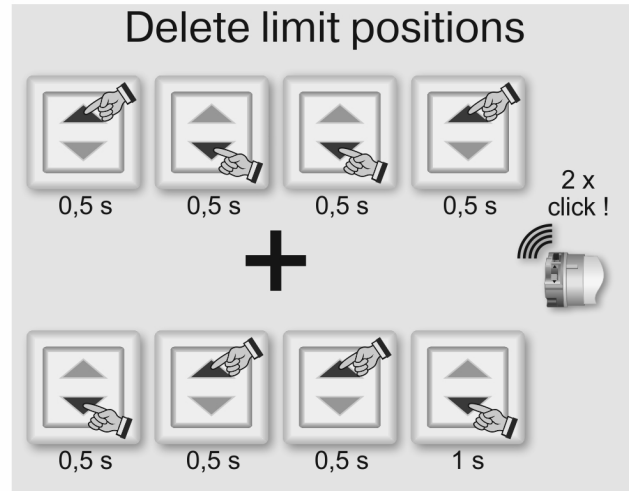

Quit Installation Mode



Intermediate Position I - Setting /

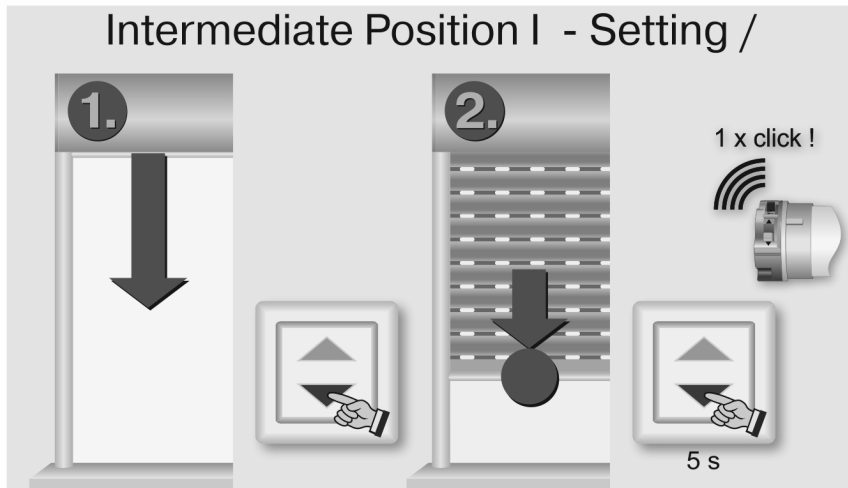

Delete Intermediate Position

